

PM rules out sabotage in tanker blast

SUN - 9 OCT 2002

PETALING JAYA: Prime Minister Datuk Seri Dr Mahathir Mohamad has said that the fire on board the Petronas-chartered crude oil carrier *Limburg* off the coast of Yemen on Sunday was caused by a short-circuit and not an act of sabotage.

"Petronas does not suspect any sabotage," he said yesterday.

He said an oil tanker could easily explode when there is a small fire caused by a short-circuit.

However, Petronas did not incur big losses from the fire as the cargo had been insured, he said.

Mahathir's views were supported by a senior US State Department official who said the explosion was accidental.

The indications tend to support a theory advanced by Yemen that the explosion had been an accident, the official said on condition of anonymity.

However, he stressed that no final conclusions about the blast had yet been made.

He said investigators from the US Navy were also en route to the stricken ship to assist French and Yemeni authorities.

The ship's owners and security experts said on Monday the explosion was more consistent with an attack than an accident.

"The indications are, at this point, that there was an explosion inside the vessel," the official said. "From the way the vessel looks, things were blown out, the plates were blown out."

That account squared with one offered earlier by a reporter at the side of the ship who said the damaged metal around the breach - big enough for a man to pass through - appeared to have been blown out rather than in.

The ship's captain, however, insisted that it was not an accident.

"The way the explosion happened, it could not have been due to a technical problem," Hubert Ardillon told reporters.

"A member of the crew told me he saw a small boat approach and I believe him. At least the first explosion occurred on the outside of the ship. I am positive about that. I saw it," AFP quoted him as saying.

"I totally rule out the theory of an

Twin-hull protection on tankers

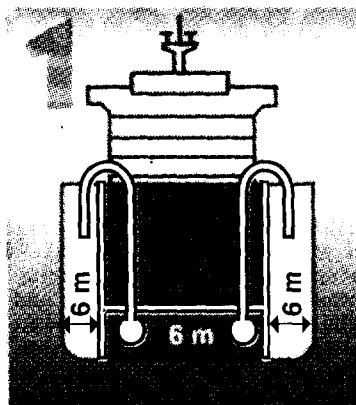

An oil tanker in working order

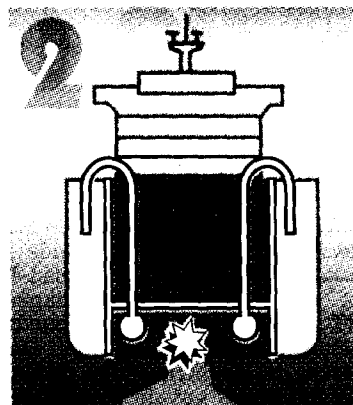

The outer hull is breached...

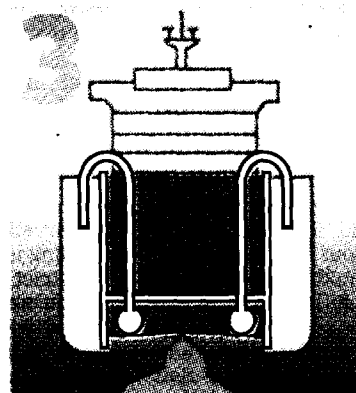

...water floods the lower tank putting pressure on the oil above

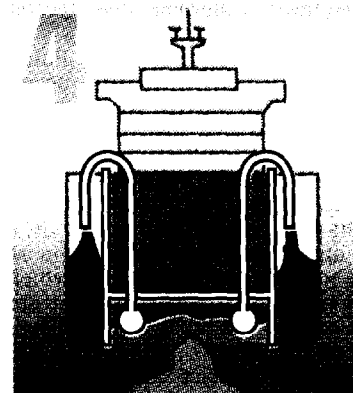

... and the hydrostatic pressure pushes the oil into the side compartments

071002

AFP

accident."

The French embassy in Sanaa said the damage was caused by a small boat packed with explosives that rammed the tanker.

But the French foreign ministry said there was no proof so far of an attack off Al-Mukalla.

"I am not talking about an attack, but I want an explanation for what happened," Ardillon said, noting he was on the bridge of the 330m-long vessel when he heard "three or four booms".

French experts were due to arrive in Yemen to join the investigation into the

exact causes.

"The ship has no weaknesses, that's clear. It was well maintained," said Ardillon in a hotel in Al-Mukalla.

He had earlier told a French newspaper in his home town of Rouen: "I've been told not to say anything. I do not have the right to talk."

Yemeni Transport and Maritime Affairs Minister Saeed Yafhi stressed that Sanaa was keen on conducting a thorough investigation to determine whether the blast was caused by technical factors or by "an act from outside" the tanker.